



**ZANOTTI Spa**  
Via M.L. King, 30  
46020 - Pegognaga (MN) - ITALY  
Tel. +39 0376 5551  
Fax +39 0376 536554  
info@zanotti.com

## Tarjeta técnica máquina

Versión 1.29

Modelo:

**MSP221NO02F**

Categoría:

**Uniblock SP-O**

### Datos técnicos

Características	U.M.	Valor
Temperatura trabajo	°C	+10 ÷ -5
Arranque		Directo
Voltaje	Volt-Ph-Hz	230/1~/50
Absorción nominal	kW*	1,00
Absorción nominal	Amp*	6,30
Corriente de arranque	Amp	34,0
Corriente máxima	Amp	12,0
Refrigerante		R404A
Desescarche		Eléctrico
Calentadores para descongelar	watt	800
Masa de la unidad condensadora	Kg	59
Masa del evaporador	Kg	19



### Compresor

Tipo		Hermético
Potencia nominal	kW	0,75

### Condensador

Volumen de aire	m³/h	1400
-----------------	------	------

### Evaporador

Volumen de aire	m³/h	1200
Proyección aire	m**	4

Categoría PED		0
---------------	--	---

### Datos de la energía

Tc °C	Ta °C	P watt	P Kcal/h	V100 m³	V80 m³	V60 m³
10	20	2974	2558	33	30	27
	25	2798	2406	31	28	26
	30	2621	2254	28	25	23
	35	2444	2102	25	23	21
	40	2267	1950	23	21	19
5	45	2090	1797	20	18	17
	20	2631	2263	28	25	23
	25	2463	2118	26	24	22
	30	2296	1975	23	21	19
	35	2129	1831	21	19	17
0	40	1962	1687	18	16	15
	45	1794	1543	17	15	14
	20	2324	1999	23	21	19
	25	2166	1863	21	19	17
	30	2010	1729	19	17	16
-5	35	1854	1594	18	16	15
	40	1699	1461	16	15	13
	45	1544	1328	14	13	12
	20	2025	1742	19	17	16
	25	1876	1613	18	16	15
-5	30	1729	1487	16	15	13
	35	1586	1364	14	13	12
	40	1447	1244	13	12	11
	45	1310	1127	11	10	9,1

\* En funcionamiento: 0 ÷ +30°C

\*\* Utilizar como mera indicación. La proyección del aire depende de numerosos factores: altura de la cámara, almacenamiento del producto, posición del evap.etc.

Tc: Temperatura cámara fría - TA:Temperatura externa.

P: Capacidad refrigerante - V: Volumen del cámara de Reccomanded

Dimensioni - Dimensions - Dimensions  
Abmessungen - Dimensiones

**SPO221**

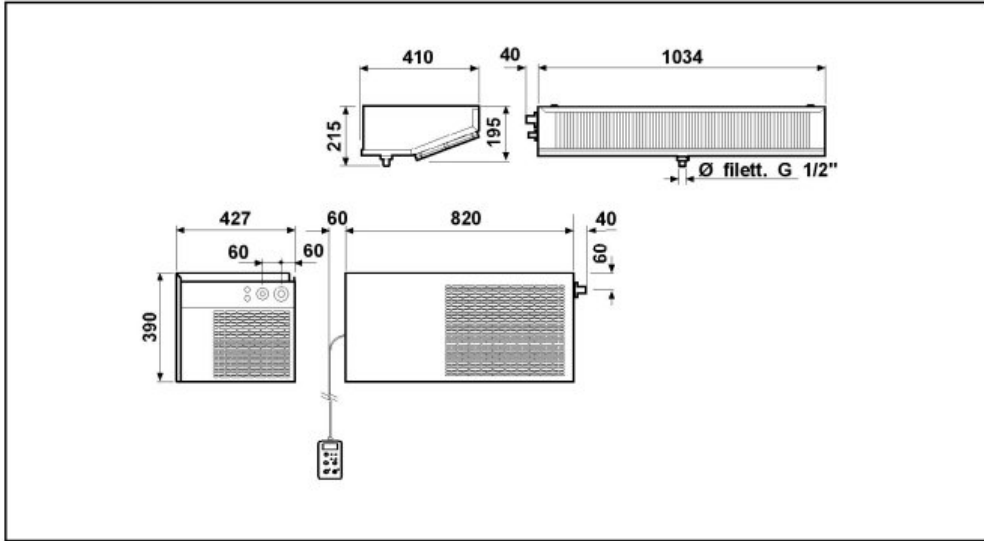

Schema di montaggio - Mounting scheme - Schema de montage  
Montageschema - Esquema de montaje

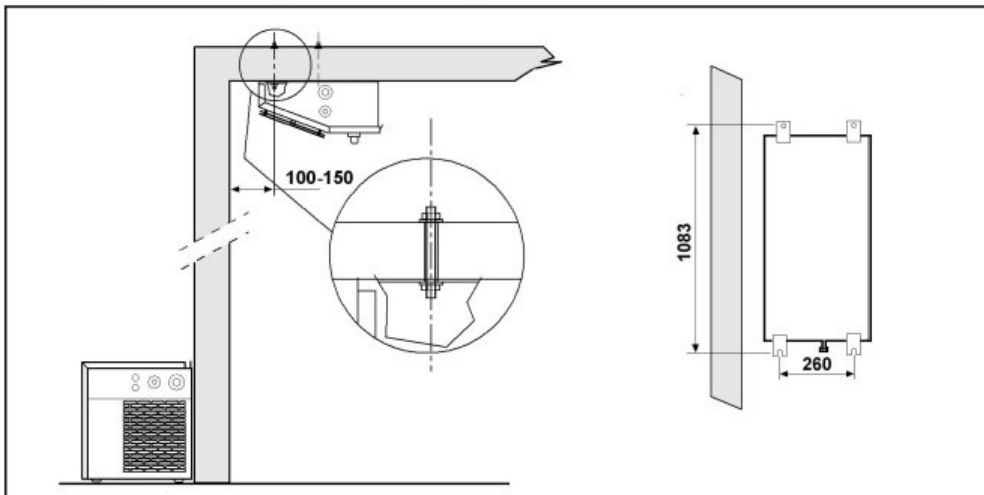

- \* Raccomandazioni in sede di installazione e per il controllo fornite sul manuale di installazione
- \* To be advised at time of order for factory installation and operating instructions
- \* Recommendations au moments d'installations et pour le contrôle fournis sur le manuel d'installation
- \* Empfehlungen für die Installationsphase und zur Kontrolle, die im Handbuch zur Installation enthalten sind
- \* Por cuanto respecta a recomendaciones de instalación y control ver manual de instalación

Massa e misure imballi - Packing mass and dimensions - Masse et dimensions emballages  
Verpackungsmasse und-abmessungen - Masa y medidas del embalaje

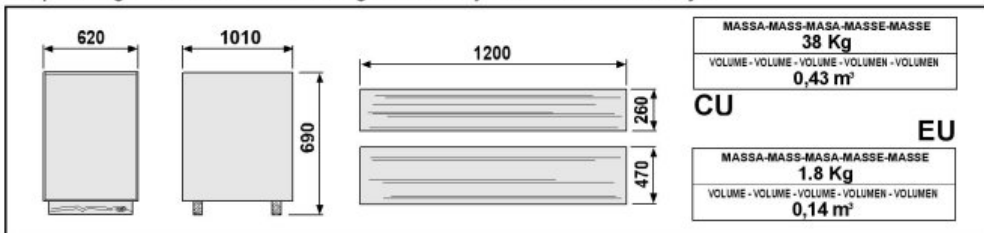

**ZANOTTI S.p.A.**