



ZANOTTI Spa
Via M.L. King, 30
46020 - Pegognaga (MN) - ITALY
Tel. +39 0376 5551
Fax +39 0376 536554
info@zanotti.com

Tarjeta técnica máquina

Versión 1.29

Modelo:

MDB221TO02F

Categoría:

Uniblock DB-O

Datos técnicos

Características	U.M.	Valor
Temperatura trabajo	°C	+10 ÷ -5
Arranque		Directo
Voltaje	Volt-Ph-Hz	400/3N~/50
Absorción nominal	kW*	1,50
Absorción nominal	Amp*	4,30
Corriente de arranque	Amp	22,0
Corriente máxima	Amp	5,9
Refrigerante		R404A
Desescarche		Eléctrico
Calentadores para descongelar	watt	800
Masa de la unidad condensadora	Kg	61
Masa del evaporador	Kg	19



Compresor

Tipo		Hermético
Potencia nominal	kW	0,92

Condensador

Volumen de aire	m³/h	1400
-----------------	------	------

Evaporador

Volumen de aire	m³/h	1200
Proyección aire	m**	4

Recipiente líquido estándar	lt	2,5
Categoría PED		1

Datos de la energía

Tc °C	Ta °C	P watt	P Kcal/h	V100 m³	V80 m³	V60 m³
10	20	3337	2870	39	35	32
	25	3193	2746	37	34	31
	30	3042	2616	34	31	28
	35	2886	2482	32	29	27
	40	2729	2347	30	27	25
5	20	2861	2460	32	29	27
	25	2715	2335	29	26	24
	30	2567	2208	27	25	22
	35	2420	2081	25	23	21
	40	2273	1955	23	21	19
0	20	2127	1829	20	18	17
	25	2037	1752	19	17	16
	30	1916	1648	17	15	14
	35	1792	1541	17	15	14
	40	1668	1434	15	14	12
-5	20	2152	1851	21	19	17
	25	2037	1752	19	17	16
	30	1916	1648	17	15	14
	35	1792	1541	17	15	14
	40	1668	1434	15	14	12
	20	2513	2161	26	24	22
	25	2379	2046	24	22	20
	30	2243	1929	22	20	18
	35	2108	1813	20	18	17
	40	1973	1697	18	16	15
	20	1840	1582	17	15	14
	25	1715	1467	15	14	12
	30	1590	1352	13	12	10
	35	1465	1237	11	10	8
	40	1340	1122	9	8	6

* En funcionamiento: 0 ÷ +30°C

** Utilizar como mera indicación. La proyección del aire depende de numerosos factores: altura de la cámara, almacenamiento del producto, posición del evap.etc.

§ Recipiente líquido: tipo alejado

Tc: Temperatura cámara fría - TA: Temperatura externa.

P: Capacidad refrigerante - V: Volumen del cámara de Reccomanded

Dimensioni - Dimensions - Dimensions
Abmessungen - Dimensiones

DBO221

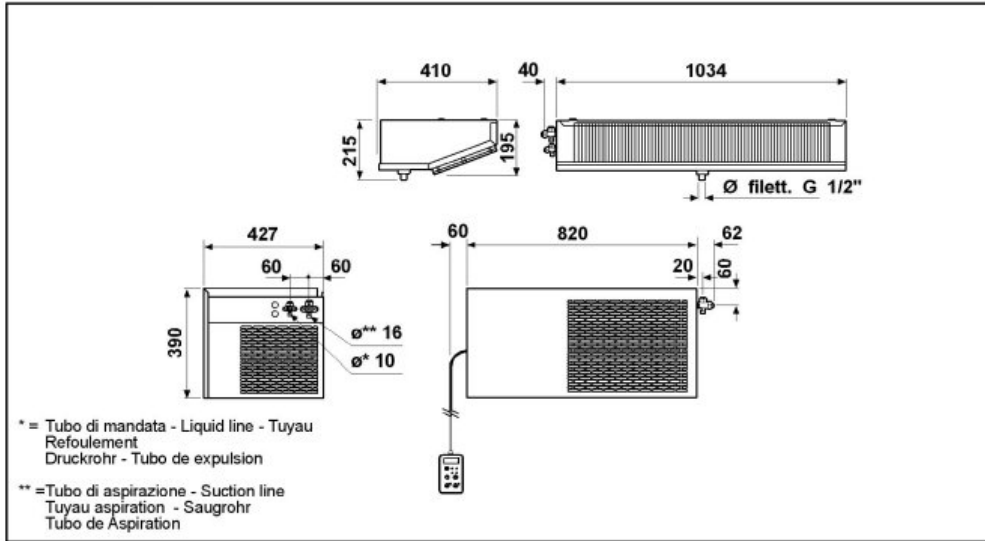

Schema di montaggio - Mounting scheme - Schema de montage
Montageschema - Esquema de montaje

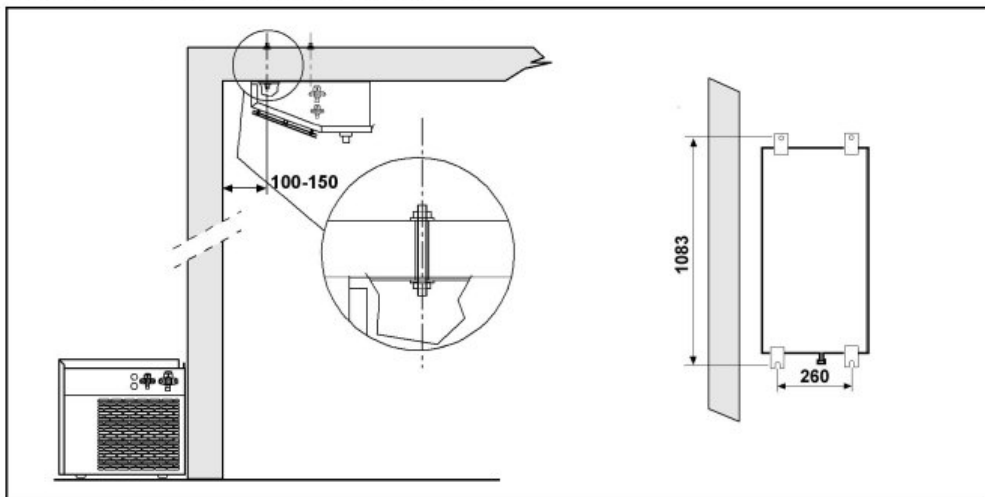

- * Raccomandazioni in sede di installazione e per il controllo fornite sul manuale di installazione
- * To be advised at time of order for factory installation and operating instructions
- * Recommendations au moments d'installations et pour le contrôle fournis sur le manuel d'installation
- * Empfehlungen für die Installationsphase und zur Kontrolle, die im Handbuch zur Installation enthalten sind
- * Por cuanto respecta a recomendaciones de instalación y control ver manual de instalación

Massa e misure imballi - Packing mass and dimensions - Masse et dimensions emballages
Verpackungsmasse und-abmessungen - Masa y medidas del embalaje

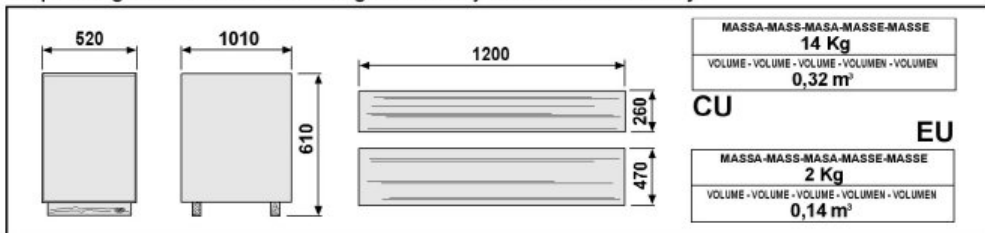

ZANOTTI S.p.A.