



ZANOTTI Spa
Via M.L. King, 30
46020 - Pegognaga (MN) - ITALY
Tel. +39 0376 5551
Fax +39 0376 536554
info@zanotti.com

Tarjeta técnica máquina

Versión 1.29

Modelo:

MDB135TO02F

Categoría:

Uniblock DB-O

Datos técnicos

Características	U.M.	Valor
Temperatura trabajo	°C	+10 ÷ -5
Arranque		Directo
Voltaje	Volt-Ph-Hz	400/3N~/50
Absorción nominal	kW*	2,40
Absorción nominal	Amp*	6,40
Corriente de arranque	Amp	28,0
Corriente máxima	Amp	10,0
Refrigerante		R404A
Desescarche		Eléctrico
Calentadores para descongelar	watt	1400
Masa de la unidad condensadora	Kg	70
Masa del evaporador	Kg	28



Compresor

Tipo		Hermético
Potencia nominal	kW	1,5

Condensador

Volumen de aire	m³/h	1500
-----------------	------	------

Evaporador

Volumen de aire	m³/h	1800
Proyección aire	m**	4

Recipiente líquido estándar	lt	2,5
Categoría PED		1

Datos de la energía

Tc °C	Ta °C	P watt	P Kcal/h	V100 m³	V80 m³	V60 m³
10	20	6208	5339	85	77	71
	25	5801	4989	78	71	65
	30	5396	4641	71	65	59
	35	4990	4291	65	59	54
	40	4585	3943	58	53	48
5	45	4181	3596	52	47	43
	20	5182	4457	68	62	56
	25	4872	4190	63	57	52
	30	4563	3924	58	53	48
	35	4254	3658	53	48	44
0	40	3945	3393	48	44	40
	45	3634	3125	43	39	36
	20	4562	3923	58	53	48
	25	4290	3689	54	49	45
	30	4019	3456	50	46	42
-5	35	3747	3222	45	41	37
	40	3473	2987	41	37	34
	45	3199	2751	37	34	31
	20	3926	3376	48	44	40
	25	3684	3168	44	40	37
-5	30	3439	2958	40	36	33
	35	3192	2745	37	34	31
	40	2943	2531	33	30	27
	45	2694	2317	29	26	24

* En funcionamiento: 0 ÷ +30°C

** Utilizar como mera indicación. La proyección del aire depende de numerosos factores: altura de la cámara, almacenamiento del producto, posición del evap.etc.

§ Recipiente líquido: tipo alejado

Tc: Temperatura cámara fría - TA: Temperatura externa.

P: Capacidad refrigerante - V: Volumen del cámara de Reccomanded

Dimensioni - Dimensions - Dimensions
Abmessungen - Dimensiones

DBO135

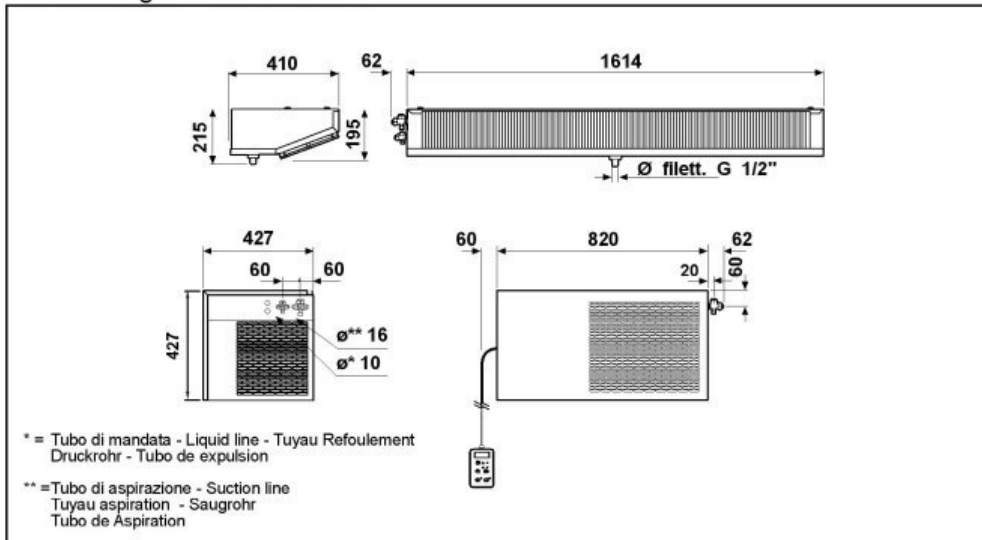

Schema di montaggio - Mounting scheme - Schema de montage
Montageschema - Esquema de montaje

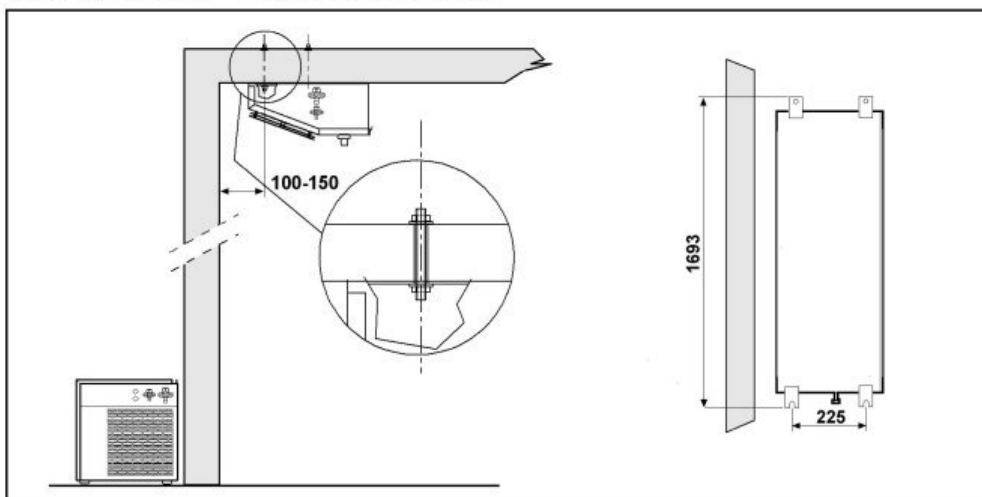

- * Raccomandazioni in sede di installazione e per il controllo fornite sul manuale di installazione
- * To be advised at time of order for factory installation and operating instructions
- * Recommendations au moments d'installations et pour le contrôle fournis sur le manuel d'installation
- * Empfehlungen für die Installationsphase und zur Kontrolle, die im Handbuch zur Installation enthalten sind
- * Por cuanto respecta a recomendaciones de instalación y control ver manual de instalación

Massa e misure imballi - Packing mass and dimensions - Masse et dimensions emballages
Verpackungsmasse und-abmessungen - Masa y medidas del embalaje

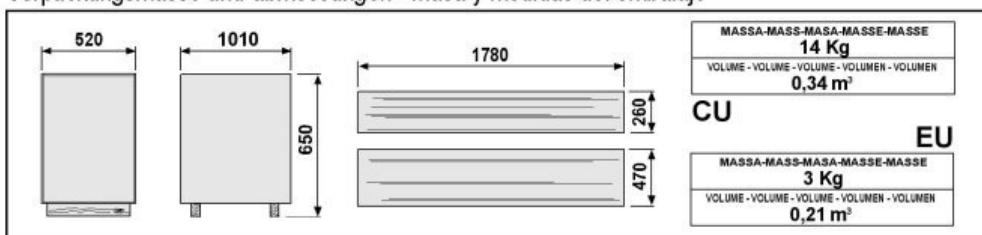

ZANOTTI S.p.A.