



ZANOTTI Spa
Via M.L. King, 30
46020 - Pegognaga (MN) - ITALY
Tel. +39 0376 5551
Fax +39 0376 536554
info@zanotti.com

Tarjeta técnica máquina

Versión 1.29

Modelo: **MDB135NO02F** Categoría: **Uniblock DB-O**

Datos técnicos

Características	U.M.	Valor
Temperatura trabajo	°C	+10 ÷ -5
Arranque		Directo
Voltaje	Volt-Ph-Hz	400/3N~/50
Absorción nominal	kW*	1,90
Absorción nominal	Amp*	5,50
Corriente de arranque	Amp	21,0
Corriente máxima	Amp	8,5
Refrigerante		R404A
Desescarche		Eléctrico
Calentadores para descongelar	watt	1400
Masa de la unidad condensadora	Kg	69
Masa del evaporador	Kg	28



Compresor

Tipo		Hermético
Potencia nominal	kW	1,1

Condensador

Volumen de aire	m³/h	1500
-----------------	------	------

Evaporador

Volumen de aire	m³/h	1800
Proyección aire	m**	4

Recipiente líquido estándar	lt	2,5
Categoría PED		1

Datos de la energía

Tc °C	Ta °C	P watt	P Kcal/h	V100 m³	V80 m³	V60 m³
10	20	5365	4614	71	65	59
	25	5037	4332	66	60	55
	30	4710	4051	60	55	50
	35	4382	3769	55	50	46
	40	4054	3486	50	46	42
5	45	3723	3202	45	41	37
	20	4654	4002	60	55	50
	25	4377	3764	55	50	46
	30	4100	3526	51	46	42
	35	3820	3285	46	42	38
0	40	3536	3041	42	38	35
	45	3247	2792	38	35	32
	20	3941	3389	48	44	40
	25	3748	3223	45	41	37
	30	3518	3025	42	38	35
-5	35	3266	2809	38	35	32
	40	3003	2583	34	31	28
	45	2743	2359	30	27	25
	20	3293	2832	38	35	32
	25	3129	2691	36	33	30
-5	30	2927	2517	33	30	27
	35	2702	2324	29	26	24
	40	2468	2122	26	24	22
	45	2240	1926	22	20	18

* En funcionamiento: 0 ÷ +30°C

** Utilizar como mera indicación. La proyección del aire depende de numerosos factores: altura de la cámara, almacenamiento del producto, posición del evap.etc.

§ Recipiente líquido: tipo alejado

Tc: Temperatura cámara fría - TA: Temperatura externa.

P: Capacidad refrigerante - V: Volumen del cámara de Reccomanded

Dimensioni - Dimensions - Dimensions
Abmessungen - Dimensiones

DBO135

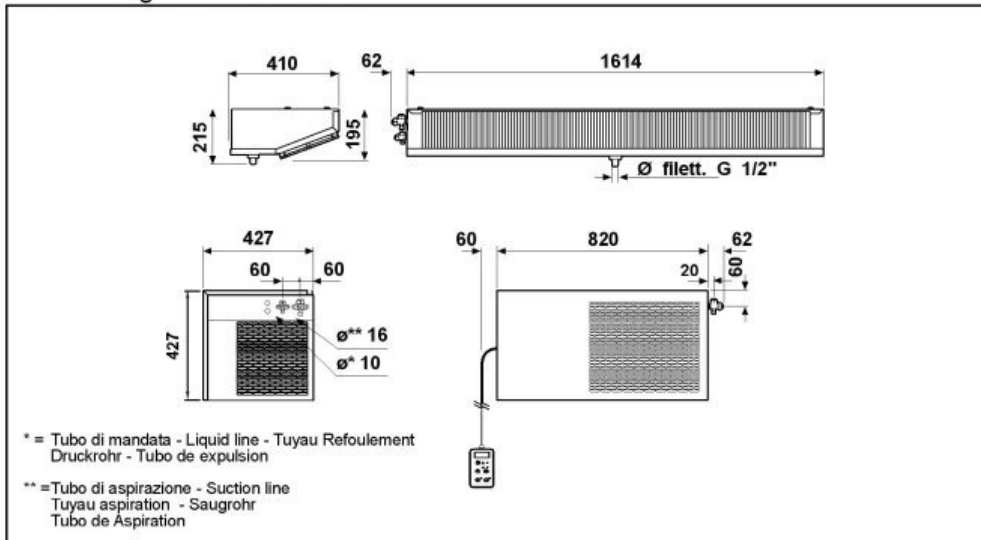

Schema di montaggio - Mounting scheme - Schema de montage
Montageschema - Esquema de montaje

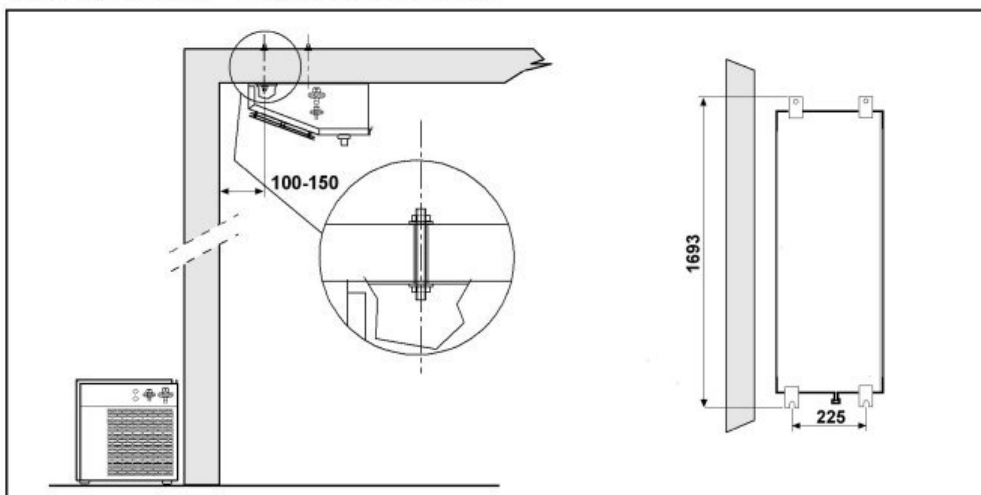

- * Raccomandazioni in sede di installazione e per il controllo fornite sul manuale di installazione
- * To be advised at time of order for factory installation and operating instructions
- * Recommendations au moments d'installations et pour le contrôle fournis sur le manuel d'installation
- * Empfehlungen für die Installationsphase und zur Kontrolle, die im Handbuch zur Installation enthalten sind
- * Por cuanto respecta a recomendaciones de instalación y control ver manual de instalación

Massa e misure imballi - Packing mass and dimensions - Masse et dimensions emballages
Verpackungsmasse und-abmessungen - Masa y medidas del embalaje

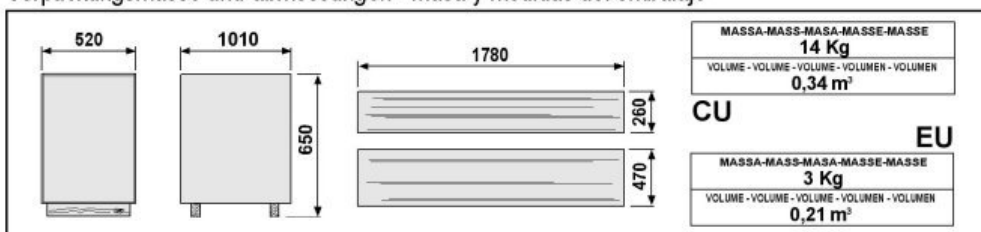

ZANOTTI S.p.A.