



ZANOTTI Spa
Via M.L. King, 30
46020 - Pegognaga (MN) - ITALY
Tel. +39 0376 5551
Fax +39 0376 536554
info@zanotti.com

Tarjeta técnica máquina

Versión 1.29

Modelo:

MAS340T1000F

Categoría:

Unidad para container

Datos técnicos

Características	U.M.	Valor
Temperatura trabajo	°C	+10 ÷ -5
Arranque		Directo
Voltaje	Volt-Ph-Hz	400/3N~/50
Absorción nominal	kW*	5,80
Absorción nominal	Amp*	13,20
Corriente de arranque	Amp	76,0
Corriente máxima	Amp	26,4
Refrigerante		R404A
Desescarche		Gas caliente
Masa	Kg	244

Compresor

Tipo		Hermético
Potencia nominal	kW	5,5

Condensador

Volumen de aire	m³/h	5600
-----------------	------	------

Evaporador

Volumen de aire	m³/h	8000
Proyección aire	m**	17

Categoría PED		2
---------------	--	---



Datos de la energía

Tc °C	Ta °C	P watt	P Kcal/h	V100 m³	V80 m³	V60 m³
	20	18575	15974	307	279	255
	25	17620	15153	288	262	239
	30	16609	14284	269	245	223
10	35	15554	13376	250	228	208
	40	14467	12442	230	209	191
	45	13359	11489	209	190	173
	20	16365	14074	265	241	220
	25	15501	13331	249	227	207
	30	14584	12542	232	211	193
5	35	13627	11719	214	195	178
	40	12641	10871	196	178	163
	45	11640	10010	178	162	148
	20	14308	12305	227	207	188
	25	13527	11633	212	193	176
	30	12710	10931	198	180	164
0	35	11872	10210	182	166	151
	40	11030	9486	167	152	139
	45	10200	8772	153	139	127
	20	12335	10608	191	174	159
	25	11678	10043	179	163	149
	30	10950	9417	166	151	138
-5	35	10175	8750	152	138	126
	40	9375	8062	138	126	115
	45	8576	7375	124	113	103

* En funcionamiento: 0 ÷ +30°C

** Utilizar como mera indicación. La proyección del aire depende de numerosos factores: altura de la cámara, almacenamiento del producto, posición del evap.etc.

Tc: Temperatura cámara fría - TA:Temperatura externa.

P: Capacidad refrigerante - V: Volumen del cámara de Recommended

Dimensioni - Dimensions - Dimensions
Abmessungen - Dimensiones

AS-R340

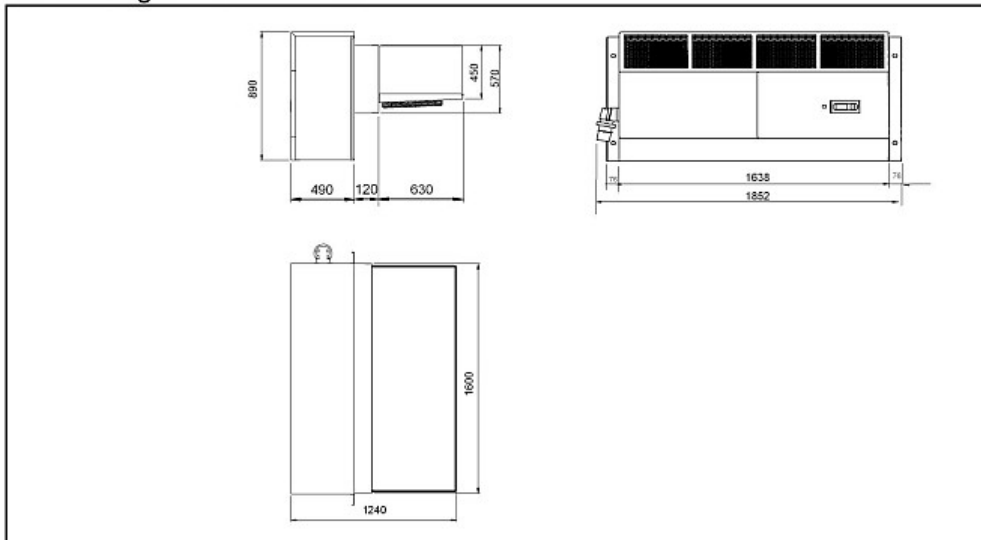

Schema di montaggio - Mounting scheme - Schema de montage
Montageschema - Esquema de montaje

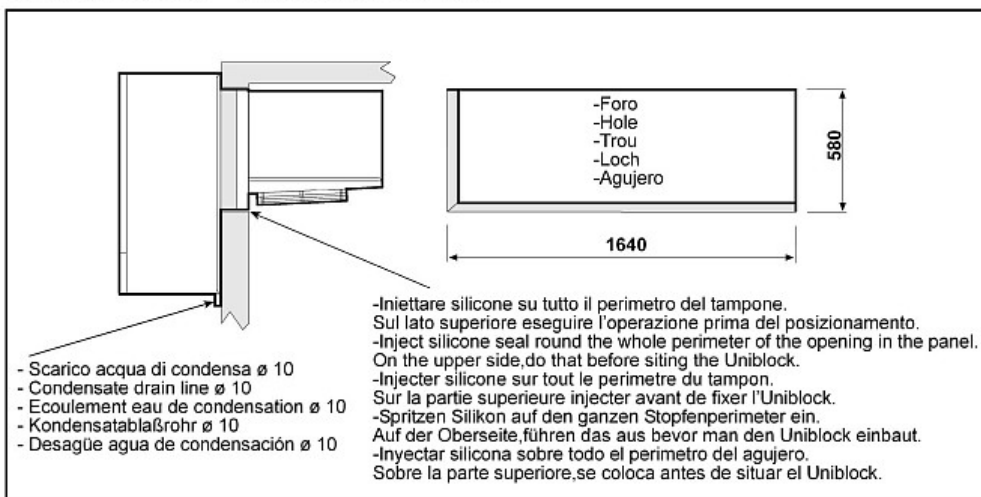

- * Raccomandazioni in sede di installazione e per il controllo fornite sul manuale di installazione
- * To be advised at time of order for factory installation and operating instructions
- * Recommendations au moments d'installations et pour le contrôle fournis sur le manuel d'installation
- * Empfehlungen für die Installationsphase und zur Kontrolle, die im Handbuch zur Installation enthalten sind
- * Por cuanto respecta a recomendaciones de instalación y control ver manual de instalación

Massa e misure imballi - Packing mass and dimensions - Masse et dimensions emballages
Verpackungsmasse und-abmessungen - Masa y medidas del embalaje

