



**ZANOTTI Spa**  
Via M.L. King, 30  
46020 - Pegognaga (MN) - ITALY  
Tel. +39 0376 5551  
Fax +39 0376 536554  
info@zanotti.com

## Tarjeta técnica máquina

Versión 1.29

Modelo: **MAS335T1000F** Categoría: **Unidad para container**

### Datos técnicos

Características	U.M.	Valor
Temperatura trabajo	°C	+10 ÷ -5
Arranque		Directo
Voltaje	Volt-Ph-Hz	400/3N~/50
Absorción nominal	kW*	4,80
Absorción nominal	Amp*	10,90
Corriente de arranque	Amp	69,0
Corriente máxima	Amp	17,8
Refrigerante		R404A
Desescarche		Gas caliente
Masa	Kg	222

### Compresor

Tipo		Hermético
Potencia nominal	kW	3,7

### Condensador

Volumen de aire	m³/h	4000
-----------------	------	------

### Evaporador

Volumen de aire	m³/h	5800
Proyección aire	m**	10

Categoría PED		2
---------------	--	---



### Datos de la energía

Tc °C	Ta °C	P watt	P Kcal/h	V100 m³	V80 m³	V60 m³
	20	14218	12227	225	205	187
	25	13566	11667	213	194	177
10	30	12869	11067	200	182	166
	35	12130	10432	187	170	155
	40	11347	9758	173	157	144
	45	10522	9049	158	144	131
	20	12525	10772	194	177	161
	25	11949	10276	184	167	153
5	30	11329	9743	173	157	144
	35	10665	9172	161	147	134
	40	9955	8561	148	135	123
	45	9201	7913	135	123	112
	20	10945	9413	166	151	138
	25	10431	8971	157	143	130
0	30	9877	8494	147	134	122
	35	9282	7983	137	125	114
	40	8642	7432	126	115	105
	45	7955	6841	114	104	95
	20	9300	7998	137	125	114
	25	8881	7638	130	118	108
-5	30	8373	7201	121	110	100
	35	7830	6734	112	102	93
	40	7308	6285	103	94	85
	45	6861	5900	96	87	80

\* En funcionamiento: 0 ÷ +30°C

\*\* Utilizar como mera indicación. La proyección del aire depende de numerosos factores: altura de la cámara, almacenamiento del producto, posición del evap.etc.

Tc: Temperatura cámara fría - TA:Temperatura externa.

P: Capacidad refrigerante - V: Volumen del cámara de Reccomanded

Dimensioni - Dimensions - Dimensions  
Abmessungen - Dimensiones

**AS-R335**

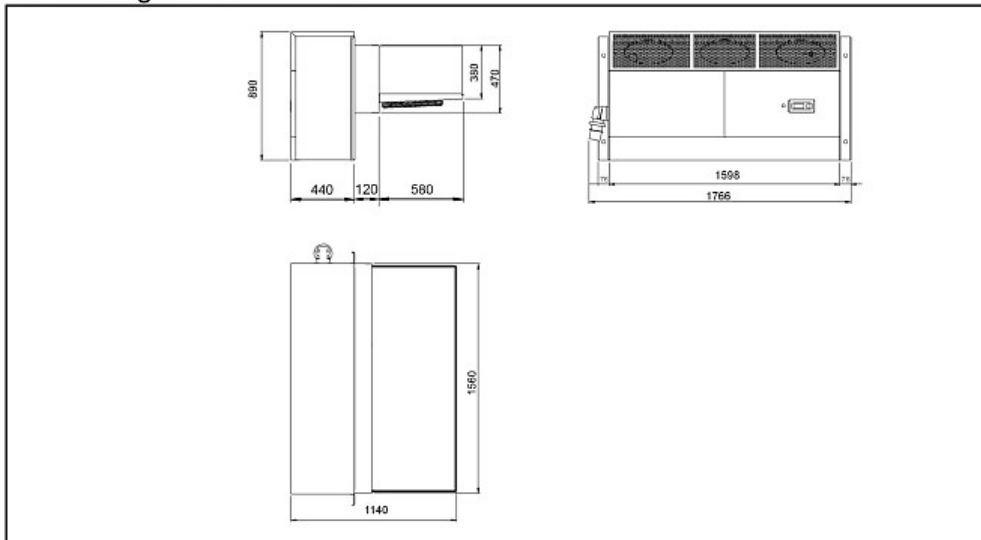

Schema di montaggio - Mounting scheme - Schema de montage  
Montageschema - Esquema de montaje

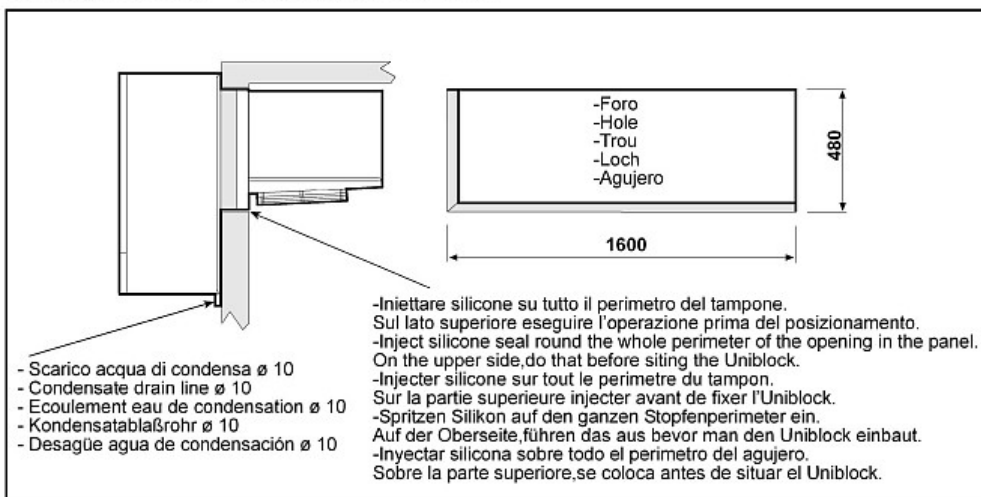

- \* Raccomandazioni in sede di installazione e per il controllo fornite sul manuale di installazione
- \* To be advised at time of order for factory installation and operating instructions
- \* Recommendations au moments d'installations et pour le contrôle fournis sur le manuel d'installation
- \* Empfehlungen für die Installationsphase und zur Kontrolle, die im Handbuch zur Installation enthalten sind
- \* Por cuanto respecta a recomendaciones de instalación y control ver manual de instalación

Massa e misure imballi - Packing mass and dimensions - Masse et dimensions emballages  
Verpackungsmasse und-abmessungen - Masa y medidas del embalaje

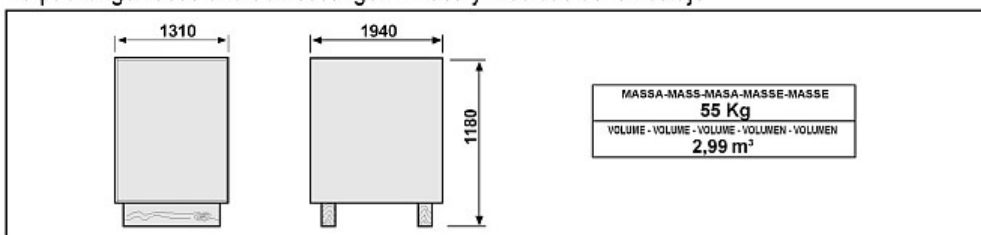

**ZANOTTI S.p.A.**