



ZANOTTI Spa
Via M.L. King, 30
46020 - Pegognaga (MN) - ITALY
Tel. +39 0376 5551
Fax +39 0376 536554
info@zanotti.com

Tarjeta técnica máquina

Versión 1.29

Modelo:

MAS335N1000F

Categoría:

Unidad para container

Datos técnicos

Características	U.M.	Valor
Temperatura trabajo	°C	+10 ÷ -5
Arranque		Directo
Voltaje	Volt-Ph-Hz	400/3N~/50
Absorción nominal	kW*	4,00
Absorción nominal	Amp*	9,20
Corriente de arranque	Amp	57,0
Corriente máxima	Amp	14,8
Refrigerante		R404A
Desescarche		Gas caliente
Masa	Kg	217

Compresor

Tipo		Hermético
Potencia nominal	kW	2,9

Condensador

Volumen de aire	m³/h	4000
-----------------	------	------

Evaporador

Volumen de aire	m³/h	5800
Proyección aire	m**	10

Categoría PED		2
---------------	--	---



Datos de la energía

Tc °C	Ta °C	P watt	P Kcal/h	V100 m³	V80 m³	V60 m³
	20	12653	10882	196	178	163
	25	12045	10359	185	168	154
10	30	11412	9814	174	158	144
	35	10749	9244	162	147	134
	40	10048	8641	150	136	124
	45	9306	8003	137	125	114
	20	11005	9464	167	152	139
	25	10515	9043	158	144	131
5	30	9956	8562	148	135	123
	35	9346	8038	138	126	115
	40	8699	7481	127	116	105
	45	8032	6908	115	105	95
	20	9572	8232	142	129	118
	25	9123	7846	134	122	111
0	30	8610	7405	125	114	104
	35	8050	6923	116	106	96
	40	7457	6413	105	96	87
	45	6850	5891	95	86	79
	20	8159	7017	117	106	97
	25	7754	6668	110	100	91
-5	30	7300	6278	103	94	85
	35	6807	5854	95	86	79
	40	6286	5406	86	78	71
	45	5745	4941	77	70	64

* En funcionamiento: 0 ÷ +30°C

** Utilizar como mera indicación. La proyección del aire depende de numerosos factores: altura de la cámara, almacenamiento del producto, posición del evap.etc.

Tc: Temperatura cámara fría - TA:Temperatura externa.

P: Capacidad refrigerante - V: Volumen del cámara de Reccomanded

Dimensioni - Dimensions - Dimensions
Abmessungen - Dimensiones

AS-R335

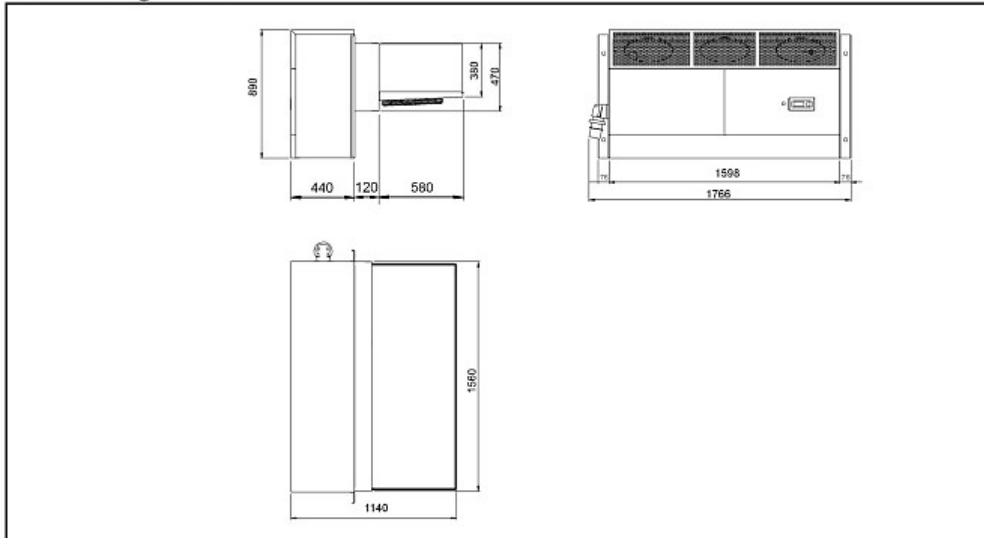

Schema di montaggio - Mounting scheme - Schema de montage
Montageschema - Esquema de montaje

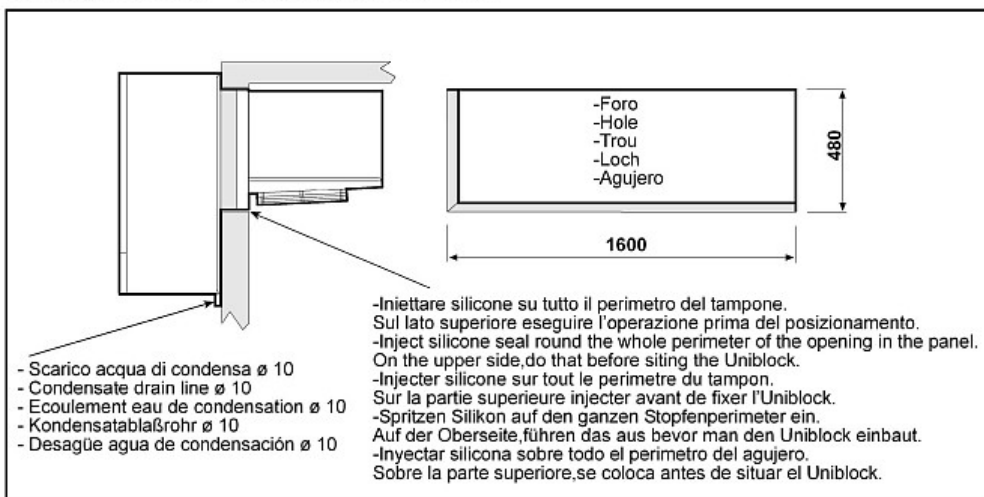

- * Raccomandazioni in sede di installazione e per il controllo fornite sul manuale di installazione
- * To be advised at time of order for factory installation and operating instructions
- * Recommendations au moments d'installations et pour le contrôle fournis sur le manuel d'installation
- * Empfehlungen für die Installationsphase und zur Kontrolle, die im Handbuch zur Installation enthalten sind
- * Por cuanto respecta a recomendaciones de instalación y control ver manual de instalación

Massa e misure imballi - Packing mass and dimensions - Masse et dimensions emballages
Verpackungsmasse und-abmessungen - Masa y medidas del embalaje

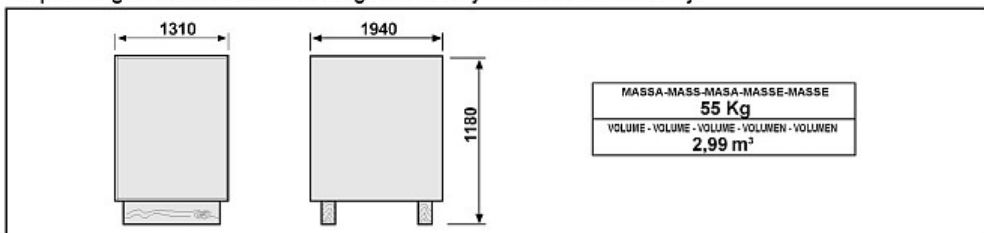

ZANOTTI S.p.A.