



**ZANOTTI Spa**  
Via M.L. King, 30  
46020 - Pegognaga (MN) - ITALY  
Tel. +39 0376 5551  
Fax +39 0376 536554  
info@zanotti.com

## Tarjeta técnica máquina

Versión 1.29

Modelo:

**MAS221T1000F**

Categoría:

**Unidad para container**

### Datos técnicos

Características	U.M.	Valor
Temperatura trabajo	°C	+10 ÷ -5
Arranque		Directo
Voltaje	Volt-Ph-Hz	400/3N~/50
Absorción nominal	kW*	1,60
Absorción nominal	Amp*	5,00
Corriente de arranque	Amp	24,0
Corriente máxima	Amp	6,5
Refrigerante		R404A
Desescarche		Gas caliente
Masa	Kg	79

### Compresor

Tipo		Hermético
Potencia nominal	kW	0,92

### Condensador

Volumen de aire	m³/h	1400
-----------------	------	------

### Evaporador

Volumen de aire	m³/h	1200
Proyección aire	m**	4

Categoría PED		0
---------------	--	---



### Datos de la energía

Tc °C	Ta °C	P watt	P Kcal/h	V100 m³	V80 m³	V60 m³
10	20	3337	2870	39	35	32
	25	3193	2746	37	34	31
	30	3042	2616	34	31	28
	35	2886	2482	32	29	27
	40	2729	2347	30	27	25
5	45	2571	2211	27	25	22
	20	2861	2460	32	29	27
	25	2715	2335	29	26	24
	30	2567	2208	27	25	22
	35	2420	2081	25	23	21
0	40	2273	1955	23	21	19
	45	2127	1829	20	18	17
	20	2513	2161	26	24	22
	25	2379	2046	24	22	20
	30	2243	1929	22	20	18
-5	35	2108	1813	20	18	17
	40	1973	1697	18	16	15
	45	1840	1582	17	15	14
	20	2152	1851	21	19	17
	25	2037	1752	19	17	16
-5	30	1916	1648	17	15	14
	35	1792	1541	17	15	14
	40	1668	1434	15	14	12
	45	1546	1330	14	13	12

\* En funcionamiento: 0 ÷ +30°C

\*\* Utilizar como mera indicación. La proyección del aire depende de numerosos factores: altura de la cámara, almacenamiento del producto, posición del evap.etc.

Tc: Temperatura cámara fría - TA:Temperatura externa.

P: Capacidad refrigerante - V: Volumen del cámara de Recommended

Dimensioni - Dimensions - Dimensions  
Abmessungen - Dimensiones

**AS-R221**

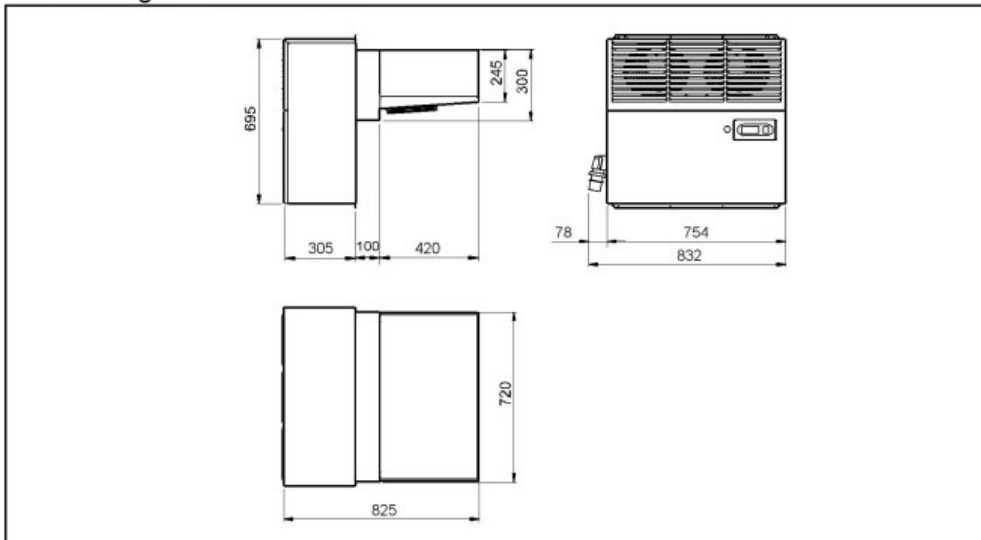

Schema di montaggio - Mounting scheme - Schema de montage  
Montageschema - Esquema de montaje

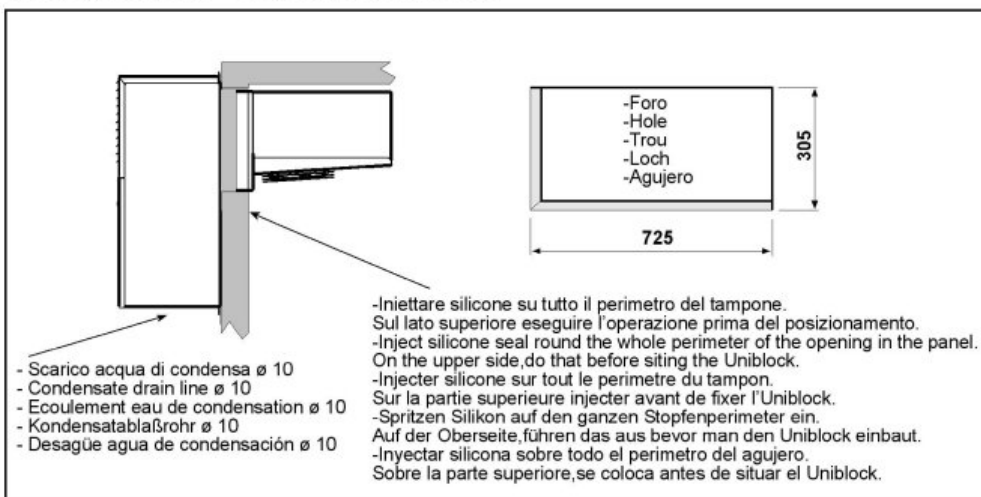

- \* Raccomandazioni in sede di installazione e per il controllo fornite sul manuale di installazione
- \* To be advised at time of order for factory installation and operating instructions
- \* Recommendations au moments d'installations et pour le contrôle fournis sur le manuel d'installation
- \* Empfehlungen für die Installationsphase und zur Kontrolle, die im Handbuch zur Installation enthalten sind
- \* Por cuanto respecta a recomendaciones de instalación y control ver manual de instalación

Massa e misure imballi - Packing mass and dimensions - Masse et dimensions emballages  
Verpackungsmasse und-abmessungen - Masa y medidas del embalaje

